

---

EM450

COFFEE MAKER



---

**DeLonghi**

**EN**

pag. 6

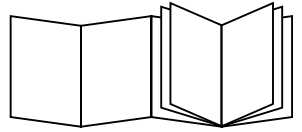

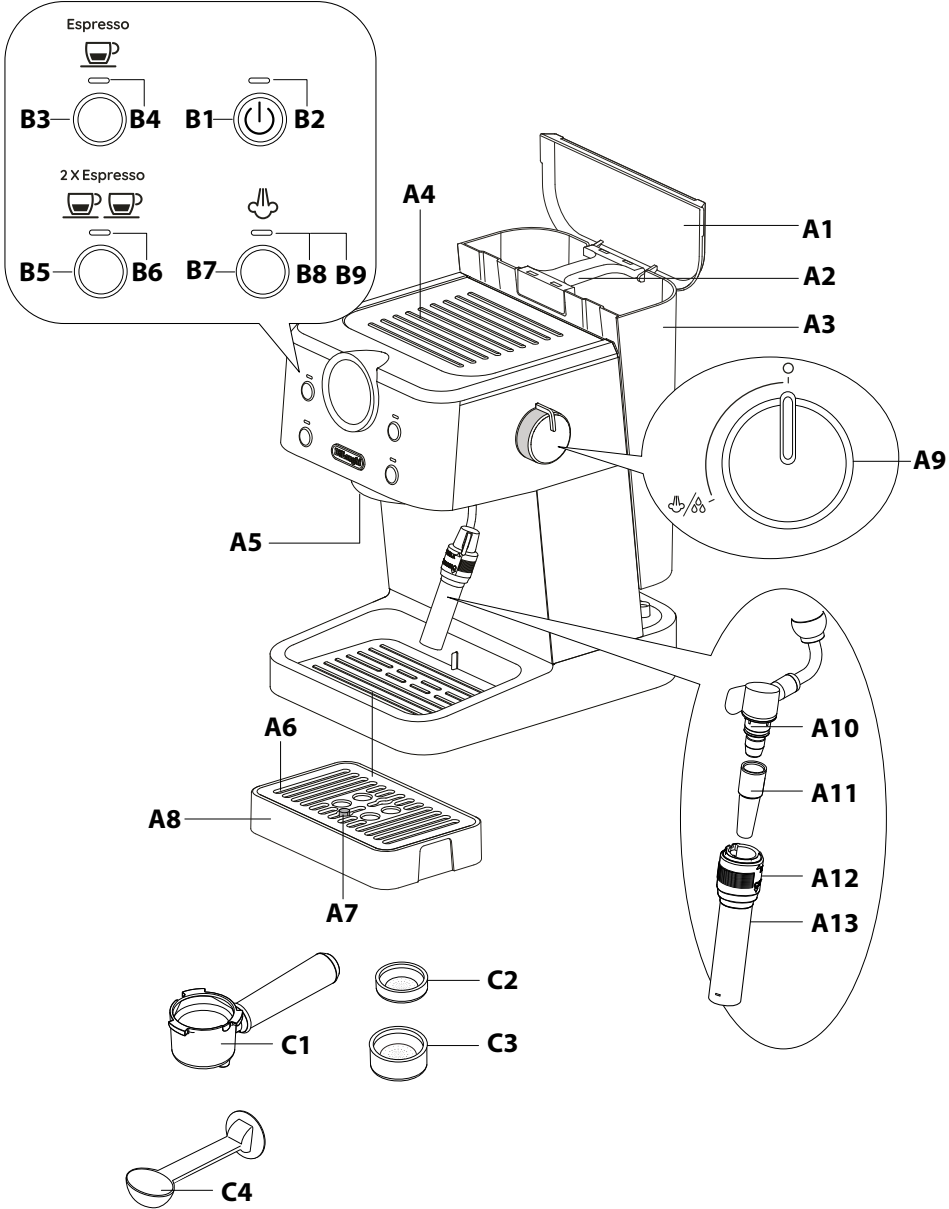

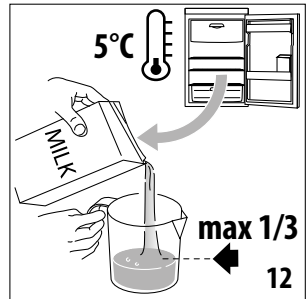
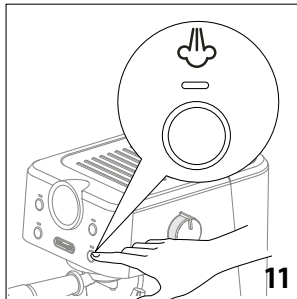
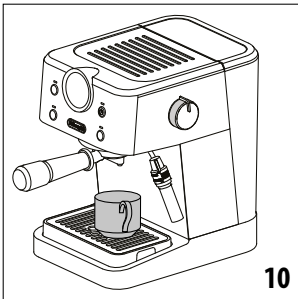
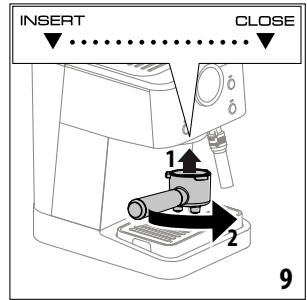
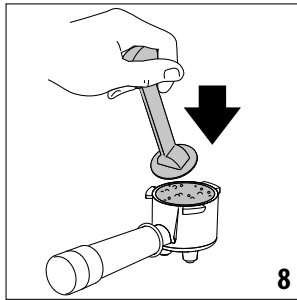
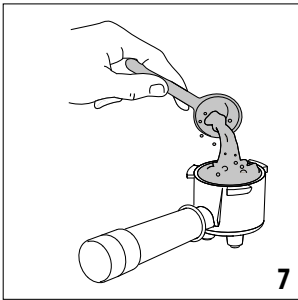
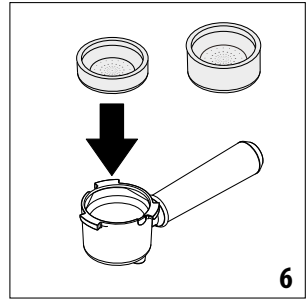
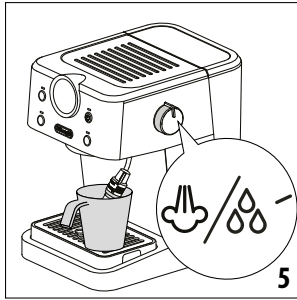
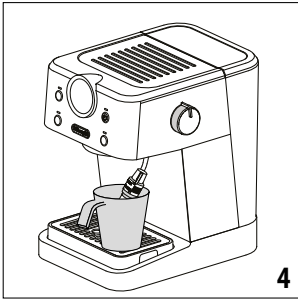
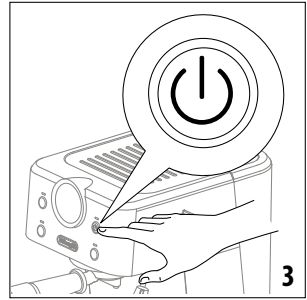
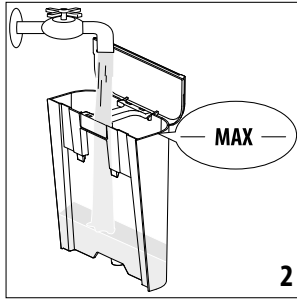
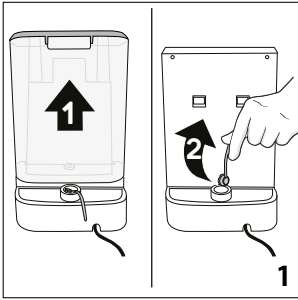

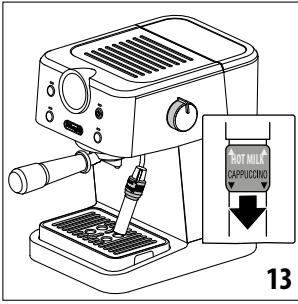

13

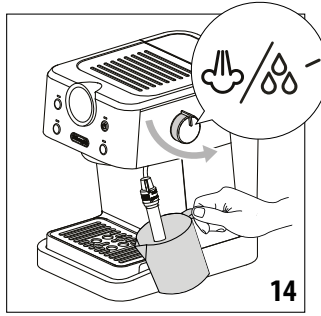

14

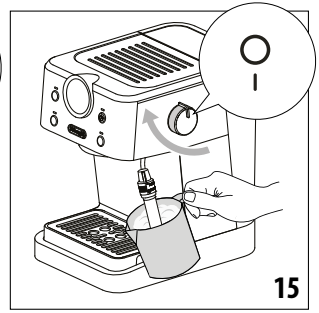

15

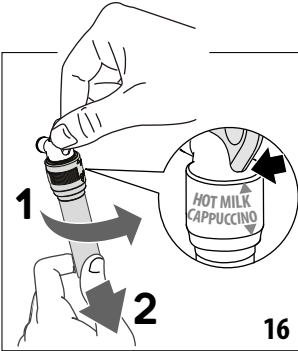

16

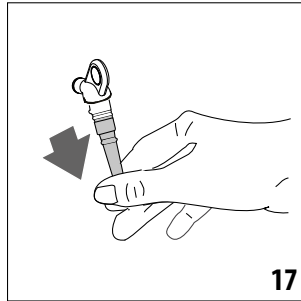

17

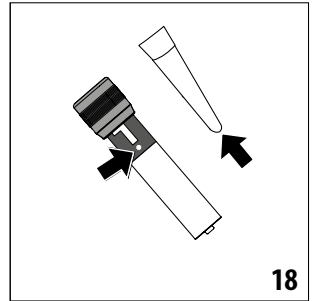

18

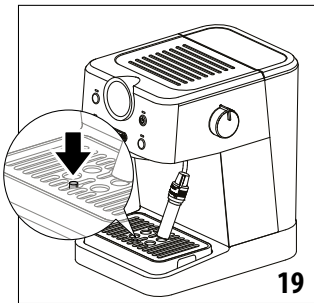

19

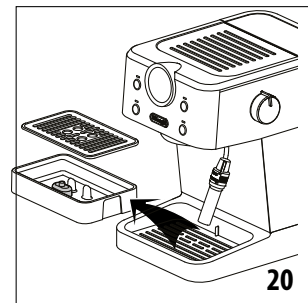

20

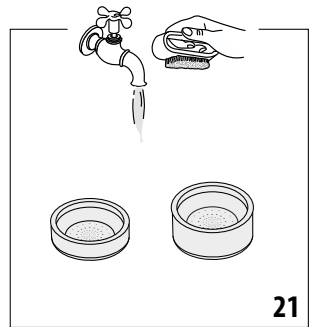

22

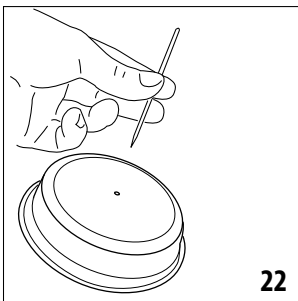

22

Before using the appliance, always read the safety warnings.

## 1. DESCRIPTION

### 1.1 Description of appliance - A

- A1. Water tank lid
- A2. Water tank handle
- A3. Water tank
- A4. Cup holder tray
- A5. Coffee spouts
- A6. Drip tray grid
- A7. Water level indicator in drip tray
- A8. Drip tray
- A9. Hot water/steam dial
- A10. Hot water/steam dispenser
- A11. Hot water/steam nozzle
- A12. Frother dial
- A13. Hot water/steam wand

### 1.2 Description of control panel - B

- B1. Main switch (ON/STAND-BY)
- B2. "ON" light (white)
- B3. 1 cup button
- B4. "1 cup" light (white)
- B5. 2 cup button
- B6. "2 cup" light (white)
- B7. Steam button
- B8. "Steam" light (white)
- B9. "Descal light" (orange)

### 1.3 Description of accessories - C

- C1. Portafilter
- C2. 1-cup filter
- C3. 2-cup filter
- C4. Scoop/Tamper

**Please note:** to identify your model, see the nameplate located on the bottom of the appliance.

## 2. PREPARING THE APPLIANCE













Wash all accessories with warm water, then proceed as follows:

1. Extract the water tank (A3) and remove the **red cap** on the base of the tank (fig. 1) and fill it with fresh clean water, taking care not to exceed the MAX level (fig. 2).
2. Reinsert the tank, pressing lightly to open the valves located on the bottom of the tank itself and paying attention it's correctly positioned (water tank adhering to the appliance).

**Important:** Never operate the appliance without water in the tank or without the tank.

## 3. SETTING UP THE APPLIANCE



When used for the first time, the internal circuits of the appliance must be rinsed as follows:

1. Plug into the mains socket. The appliance runs a self-diagnosis cycle, indicated by the sequential flashing of all the lights , , , .
2. Press the main switch  (B1) (fig. 3).
3. The lights  and  flash, indicating that the appliance is heating up: when the lights are steadily lit, the appliance is ready.
4. Attach the portafilter to the appliance with the filter inserted; align the portafilter handle with "INSERT", then rotate to the right until the handle is aligned with "CLOSE" (fig. 9).
5. Place a container with a capacity of at least 0,5 liter under the coffee spout (A5).
6. Press the button . Repeat this procedure 3 times.
7. Empty the container and place it under the hot water/steam dispenser (fig.4).
8. Turn the steam dial (A9) to position /88 (fig. 5) and dispense hot water: the appliance automatically stops dispensing and the lights ,  and  flash. Turn the knob back to position "O".

The appliance is ready for use.

**Please note:** It is normal for there to be water in the space under the tank. This should therefore be dried regularly with a clean sponge.

## 4. MAKING COFFEE

1. Place the ground coffee filter (C2) or (C3) in the portafilter (C1) (fig. 6).
2. Fill the filter with ground coffee (fig. 7). Make sure to use finely ground coffee specifically for espresso (1 scoop for 1 cup, 2 scoop for 2 cups).
3. Distribute the ground coffee evenly and press down gently with the tamper (C4) (fig. 8).
4. Remove any excess coffee from the rim of the portafilter and attach it to the appliance (fig. 9).
5. Place the cup or cups under the portafilter spouts (C1).
6. Make sure the lights corresponding to the coffee buttons are on, then press the coffee button  (B3) or  (B5).
7. The appliance proceeds to make the coffee and delivery stops automatically.
8. To remove the portafilter, turn the handle from right to left.

**Please note:**

- For correct operation, before filling with ground coffee, check that the filter has no coffee powder residue from the previous brew.

- While the appliance is making coffee, delivery can be interrupted at any moment by pressing the coffee button pressed previously.
- At the end of delivery (within 3 seconds), to increase the amount of coffee in the cup, press and hold the coffee button pressed previously. Delivery stops when the button is released (maximum 10 seconds).
- To avoid splashes, never remove the portafilter while the appliance is delivering coffee. Always wait for a few seconds after delivery.

#### 4.1 Pressing the coffee:

Correct tamping of the ground coffee is essential to obtain a good espresso.

- If you press too firmly, the coffee will be delivered slowly and the taste will be more intense.
- If you press too lightly, the coffee will be delivered quickly and the flavor will be very light.

#### 4.2 Tips for a hotter coffee



- Before making the coffee, warm the cups by rinsing them with a little hot water.
- Attach the portafilter (C1) with the filter (C2) or (C3) to the appliance, **but without adding coffee**. Using the same cup as will later be used to make the coffee, press the 1 cup or 2 cups button and deliver hot water into the cup to heat it.
- Stand the cups you will be using on the cup holder tray (A4) which becomes hot during operation.



#### **Please note:**

It is completely normal for the pressure gauge needle moving in the optimal zone during the brewing unit rinsing phase.

#### 4.3 Programming the quantities of coffee in the cup



The appliance is set by default to automatically deliver standard quantities. To change these quantities, proceed as follows:

1. Place one or two cups under the portafilter spouts (C1).
2. Press and hold the button you want to program (  or  ).
3. The coffee maker starts delivering coffee. After 5 seconds the programming mode starts and the coffee button will emit intermittent flashes.
4. Once the required quantity of coffee has been delivered into the cup, release the button, the light flashes three times. Delivery stops and the light flashes to indicate that the quantity has been saved correctly.

	Programmable quantity
	maximum 90 ml
	maximum 160 ml

**Please note:** The programmed quantity could change with different type of coffees.

### 5. HOW TO MAKE CAPPUCCINO

1. Prepare the espresso coffee as described in section 4. MAKING COFFEE, using sufficiently large cups.
2. Press  button (fig. 11): the light flashes;
3. In the meantime, fill a container with about 100 ml of milk for one cappuccino (fig.12). For more than one cappuccino, repeat the following operations. For dense and consistent froth, skim or semi-skimmed refrigerated milk (about 5° C) should be used. When choosing the size of the container, consider that the milk will increase in volume approximately two fold.
4. Check that the frother dial (A12 ) is set to “CAPPUCCINO” (fig. 13);
5. Wait for the  button to light up steadily, indicating that the heating element has reached the ideal temperature to produce steam.
6. Place an empty container under the frother and open the dial for a few seconds to purge any water in the circuit. Close the dial again.
7. Place the container with the milk under the frother.
8. Immerse the frother in the milk container, taking care never to immerse the black-coloured ring (fig. 14). Turn the dial to position . The frother dispenses steam and air that will texture the milk into foam and increases its volume. To increase texturing, immerse the frother into the milk and move the container slowly in circular motions, from the bottom up.
9. When the temperature (ideally 60°C) and desired texture have been reached, stop the steam supply by turning the steam dial to position “○” (fig. 15).
10. Pour the frothed milk into the cups containing the espresso coffee prepared previously. The cappuccino is ready: add sugar to taste and, if desired, sprinkle some cocoa powder over the froth.
11. To exit the steam function, press any of the buttons.

#### **Please note:**

- to prepare more than one cappuccino, make all the coffees first, then prepare the frothed milk for all the cappuccinos at the end;

You should not deliver steam for more than 60 seconds.

### 5.1 Preparing hot milk

To prepare hot, unfrothed milk, follow the instructions listed in 5. HOW TO MAKE CAPPUCCINO, making sure the frother dial (A12) is positioned upwards, set to "HOT MILK".

### 5.2 Cleaning the frother after each use

#### Important:

For hygiene reasons, the frother should be cleaned after each use.

Proceed as follows:

1. Release any trapped steam for a few seconds (points 2, 5 and 6 above), rotating the steam dial. This procedure will drain any milk trapped inside the frother. Turn off the appliance pressing on the ON/OFF button (B1).
2. Wait a few minutes for the frother to cool: with one hand, hold the frother wand still and with the other, release the frother itself by twisting it counter-clockwise, then pull it downwards (fig. 16).
3. Remove the rubber steam nozzle from the wand, pulling it downwards (fig. 17).
4. Push the ring upwards and check that the holes indicated by the arrow in fig. 18 are not blocked. If necessary, clean with the help of a pin;
5. Re-fit the nozzle, moving the ring downwards, then reinsert the frother on the nozzle, turning and pushing it upwards until it clicks in.

### 5.3 Cooling cycle

If after using the steam function you want to go back to coffee, press any of the buttons: the three ☕ / ☕☕ and ☝ lights flash simultaneously, indicating that the heating element needs to cool down to reach the correct espresso temperature, proceed as follows:

- Make sure to have water in the water tank and place a container under the Hot water/steam dispenser (A10);
- open the steam dial to dispense steam and hot water, when the heating element has cooled, dispensing stops, the lights ☕ / ☕☕ and ☝ flash quickly, then close the steam dial. The appliance is now ready for use.









## 6. HOT WATER

1. Place a container under the hot water/steam dispenser (A10).
2. Wait for the coffee lights ☕ and ☕☕ to turn on.
3. Turn the steam (A9) dial to ☝/☕. Hot water will come out of the hot water/steam dispenser.

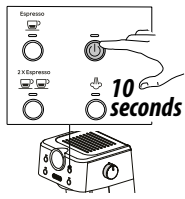
4. The light ☕ and ☕☕ will blink during the hot water erogation.
5. To stop the flow of hot water, turn the dial to "0".

You should not deliver hot water for more than 60 seconds.

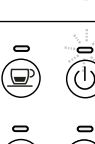
## 7. SETTINGS MENU

1. Access the menu:			
Press and hold the  button at least 10 seconds until the  light flashes.			
2. Auto-off			
Corre- sponding setting	Press to select the setting	Press to change the setting	LED reference
<b>Auto-off</b>    The machine shows the preset values	Press and hold the  button at least 1 second	Press ☕ at least 1 sec. to select <b>9 minutes</b>	
		Press ☕☕ at least 1 sec. to select <b>30 minutes</b>	
		Press ☝ at least 1 sec. to select <b>3 hours</b>	
Once selection set the  light flashes 5 times to indicate that the selections as taken place and the machine is ready to use.			

#### Please note:





- The light corresponding to the changed setting flashes quickly to confirm the change.

- After 1 minute of inactivity, the machine automatically exits the settings menu and is ready for use.

## 8. DEFAULT COFFEE QUANTITY (RESET)

This resets the machine to the default values.

Proceed as follows:

- To reset the single coffee press  and  buttons for 5 seconds, the lights will flash for three times.
- To reset the double coffee press  and  buttons for 5 seconds, the lights will flash for three times.

The appliance is now ready for use.

## 9. CLEANING THE MACHINE

The following parts of the machine must be cleaned regularly:

- drip tray (A8)
- coffee filters (C2), (C3);
- coffee spout (A5);
- water tank (A3);
- the hot water/steam dispenser as indicated in chapter “5.2 Cleaning the frother after each use”;

### **Important!**

- None of the components or accessories is dishwasher safe.
- Do not use solvents, abrasive detergents or alcohol to clean the coffee machine.
- Do not use metal objects to remove encrustations or coffee deposits as they could scratch metal or plastic surfaces.
- If the appliance is not used for more than a week, before using it again, we recommend performing a rinse cycle as described in chapter “3. Setting up the appliance”.

### **Danger!**

- Never immerse the coffee maker in water when cleaning: it is an electrical appliance.
- Before commencing any cleaning operation on the outside of the machine, turn it off, unplug it from the mains socket and wait for it to cool down.

### 9.1 Cleaning the drip tray

#### **Important!**

The drip tray is fitted with a level indicator (red) showing the level of water it contains.

Before the indicator starts to protrude from the cup tray (fig. 19), the tray must be emptied and cleaned, otherwise the water may spill over the edge and damage the appliance, the support surface or the surrounding area.

1. Remove the tray (A8) (fig. 20).
2. Remove the drip tray grid (A6), eliminate the water and clean the tray with a cloth, then reassemble the drip tray. Put the drip tray back in place.

### 9.2 Cleaning the coffee filters

The coffee filters are designed to achieve the best possible coffee froth. To keep them efficient, they must always be kept clean and free of any coffee residue.

- After each use, rinse the filter under plenty of running water (fig. 21).
- Check that the hole on the back of the filter (see fig. 22) is free of any residue.

If the filter is still dirty, or in any case at least once a month, clean the coffee filters as follows:

1. Rinse the filters under running water (fig. 21).
2. Make sure the holes are not blocked. If necessary, clean with a pin (fig. 22).
3. Wipe dry with a cloth.

### 9.3 Cleaning the coffee spouts

After every 200 coffees, rinse by delivering about 0.5 litres of water from the spouts (press the coffee button without using ground coffee).

### 9.4 Other cleaning operations

1. Do not use solvents or abrasive detergents to clean the coffee maker. Use a soft damp cloth only.
2. Clean the portafilter cup.

### 9.5 Cleaning the water tank

Periodically (about once a month) clean the water tank (A3).

1. Take out the water tank and rinse with drinking water;
2. Empty the water tank and clean with warm water (40°C approx), wiping if necessary with a clean, non-abrasive cloth. Rinse thoroughly under running water;
3. Fill the water tank with fresh drinking water up to the MAX level and return it to the machine.

#### **Please note:**

- If the machine has not been used for more than 3 days, clean the water tank as described above

## 10. DESCALING

When the orange  light ON, run a descaling cycle.

#### **Important!**

- Before using the descaler, read the instructions and the labelling on the pack.
- It is important to use only the De'Longhi descaler. Using an unsuitable descaler and/or performing descaling incorrectly may result in faults not covered by the manufacturer's warranty.
- Descaler can cause damage to delicate surfaces. If the product is accidentally spilt, dry immediately.

To descale		
Descaler	ECODECALK	www.delonghi.com
Container	Capacity 1 L	
Time	~25min	

1. Check that the portafilter is not attached and place a 1 liter capacity container under the hot water dispenser and under the coffee spouts.
2. Pour the descaler solution into the tank (level A), diluting the supplied descaler with water (level B) (fig.23).

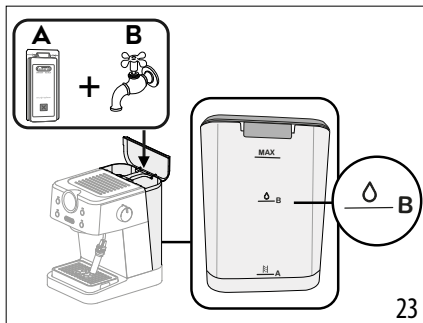

3. Press ☕ button, the descaler solution will be delivered through the coffee spouts. Once the erogation stops from the coffee spouts open the steam dial and keep it open till erogation stops.
4. Wait two minutes before repeating point 3 till water in the tank runs out.

You now need to rinse the appliance.

5. Empty the container used to collect the descaler solution and reposition it under the spouts.
6. The machine is ready for rinsing with fresh, potable water. Extract the water tank, empty and rinse it under running water, fill it with fresh water (fig. 24) and put it back in the appliance.
7. Repeat point 3 till water in the tank runs out.

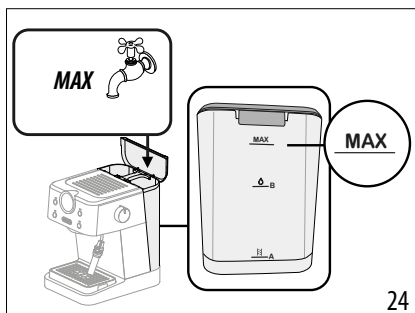





To reset descaling light (orange ☕ light), press the ☕ button for 10 seconds, first the orange light then the white light will flashes to indicate that the descaling alarm is resetted.

Before making coffee please clean the machine throughtly, the drip tray and the hot water/steam dispenser.

## 11. TECHNICAL DATA

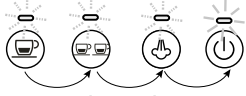
Mains voltage: .....220-240V~ 50-60Hz  
 Absorbed power:..... 1325 W  
 Pressure: ..... 15 bar  
 Water tank capacity: .....1,7 l  
 Size WxDxH .....226x283x310 mm  
 Weight .....4.1 kg

## 12. EXPLANATION OF INDICATOR LIGHTS

Lights	Meaning	Solution
	The appliance is plug into the mains socket	The appliance performs a self-diagnosis cycle, indicated by sequential flashing of the lights
	The ON/OFF (B1) button is turned on	Flashing lights: the appliance is heating up Lights on steadily: the appliance is ready
	Steam dial open	Close the steam dial
	Cooling cycle required	See "5.3 Cooling cycle"
	The steam function is required	Flashing light: the appliance is heating up to deliver steam Light on steadily: the appliance is ready to deliver steam
	Steam orange light on, descaling process is necessary	Descal the appliance (see paragraph 10).

## 13. TROUBLESHOOTING

Problem	Cause	Solution
Espresso coffee is not delivered any more	No water in the tank	Fill the tank
	The holes in the portafilter are blocked	Clean the portafilter spout holes
	The filter is blocked	Clean as described in section "9.2 Cleaning the coffee filters"
	The tank has been inserted incorrectly and the valves on the bottom are not open	Press the tank down lightly to open the valves on the bottom
	Limescale in the water circuit	Descal as described in section "10. Descaling"
The espresso coffee drips from the edges of the portafilter rather than the holes	The portafilter has been inserted incorrectly or is dirty	Attach the portafilter correctly and rotate firmly as far as it will go, if dirty, follow par. 9.2 and 9.3
	The seal of the coffee spout has lost flexibility or is dirty	Have the seal of the coffee spout replaced by Customer Services
	The holes in the portafilter spouts are blocked	Clean the portafilter spout holes
	The filter is blocked	Clean as described in section "9.2 Cleaning the coffee filters"
The portafilter cannot be attached to the appliance	Too much coffee has been placed in the filter	Use the measure supplied and make sure you are using the correct filter for the type of preparation
→		

<b>Problem</b>	<b>Cause</b>	<b>Solution</b>
The espresso crema is too light	The pre-ground coffee is not tamped down firmly enough	Tamp the pre-ground coffee more firmly
	There is not enough pre-ground coffee	Increase the quantity of pre-ground coffee
	The pre-ground coffee is too coarse	Use only pre-ground coffee for espresso coffee makers
	The wrong type of pre-ground coffee is being used	Change the type of pre-ground coffee
The espresso crema is too dark	The pre-ground coffee is tamped down too firmly	Tamp the coffee down less firmly
	The quantity of ground coffee is too high	Reduce the quantity of ground coffee
	The coffee spouts is blocked	Clean as described in section "9.3 Cleaning the coffee spouts"
	The filter is blocked	Clean as described in section "9.2 Cleaning the coffee filters"
	The pre-ground coffee is too fine	Use only pre-ground coffee for espresso coffee makers
	The ground coffee is too fine	Use pre-ground coffee for espresso coffee makers only
	Limescale in the water circuit	Descale as described in section "10. Descaling"
After delivering coffee, the filter remains attached to the coffee spouts		Insert the portafilter again, deliver coffee, then remove the portafilter
No milk froth is formed when making cappuccino	The dial is set to "HOT MILK"	Move the dial to "CAPPUCCINO"
	Milk not cold enough	Always use milk at refrigerator temperature
	Steam wand dirty	Clean the cappuccino maker as described in section "5.2 Cleaning the frother after each use"
	Limescale in the water circuit	Descale as described in section "10. Descaling"
The machine does not function and all the lights flash		Disconnect the machine immediately and contact authorised Customer Services
The pressure gauge needle is positioned in the gray dotted area	It is completely normal for the pressure gauge needle to be positioned in the grey dotted area during the heating phases, water/steam delivery, brew unit rinsing and coffee pre-infusion	
The pressure gauge needle is positioned in the red dotted area	There is too much pressure inside the machine	Disconnect the appliance from the mains and turn the steam dial (A9) to  in order to discharge pressure, afterwards, slowly remove the portafilter and let it cool down with fresh water before cleaning the portafilter spouts holes.

**Register Now**

[www.delonghi.com/register](http://www.delonghi.com/register)

